

TIMELESS
TREASURES

Sunflower Serenade







Wing and a Prayer
design









Photo: D. James Dee

Finished Quilt Size: 67" x 83" • Finished Block Size: 15"

Fabric Requirements

-  Fabric 1: One Fat Quarter JT C5840 CREAM (tonal vine)
-  Fabric 2: One Fat Quarter JT C5841 CREAM (tonal check)
-  Fabric 3: One Fat Quarter JT C5837 YELLOW (tonal)
-  Fabric 4: One Fat Quarter JT-C5837 GOLD (tonal)
-  Fabric 5: 1/2 yard JT-C6713 CREAM (daisy)
-  Fabric 6: 1/2 yard JT-C5840 RED (vine)
-  Fabric 7: 1/2 yard JT-C5837 PINE (tonal)

-  Fabric 8: 2 yards JT-C5837 RED (tonal)
 -  Fabric 9: One Fat Quarter, JT-C6714 NAVY (wheat-sunflower)
 -  Fabric 10: One Fat Quarter, JT-C6714 CREAM (wheat-sunflower)
 -  Fabric 11: 1/2 yard JT-C6711 CREAM (big sunflower)
 -  Fabric 12: 1/2 yard JT-C6711 NAVY (big sunflower)
 -  Fabric 13: 2/3 yard ERA-C9320 CHOCOLATE (tonal leaf)
 -  Fabric 14: 2 1/2 yards JT-C6712 NAVY (sunflower stripe)
- 4 yards JT-C6711 CREAM (Backing)

Cutting Instructions

- *Fussy Cutting (fabrics 9 & 10):* Using a pencil, mark the designated square size centering the motif and cut out. Be careful when cutting not to slice into other motifs you may want to use later.
- *Selective Cutting (fabrics 11 & 12):* Less exact than fussy cutting, selective cutting may be used when several motifs in a print are usable. For best use of the fabric, we started with a 5 1/2" x WOF strip and selectively cut 4 1/2" corner squares. Refer to corner squares in quilt photo as a guide when cutting.

From Fabric 1 (JT C5840 CREAM), cut two 5 3/4" x 22". Sub-cut into six 5 3/4" squares.

From Fabric 2 (JT C5841 CREAM), cut two 5 3/4" x 22". Sub-cut into six 5 3/4" squares.

From Fabric 3 (JT C5837 YELLOW), cut two 5 3/4" x 22". Sub-cut into six 5 3/4" squares.

From Fabric 4 (JT-C5837 GOLD), cut:

- Two 5 3/4" x 22". Sub-cut into six 5 3/4" squares.
- One 1 1/2" x 22". Sub-cut into twenty 1 1/2" squares.

From Fabric 5 (JT-C6713 CREAM), cut six 2" x WOF. Sub-cut into forty-eight 2" x 4 1/2".

From Fabric 6 (JT-C5840 RED), cut six 2" x WOF. Sub-cut into forty-eight 2" x 4 1/2".

From Fabric 7 (JT-C5837 PINE), cut seven 2" x WOF. Sub-cut into forty-eight 2" x 6".

From Fabric 8 (JT-C5837 RED), cut:

- Four 5 3/4" x WOF. Sub-cut into twenty-four 5 3/4" squares.
- Three 2 1/2" x WOF. Sub-cut forty-eight 2 1/2" squares.
- Sixteen 2" x WOF

From Fabric 9 (JT-C6714 NAVY), FUSSY CUT six 4 1/2" squares.

From Fabric 10 (JT-C6714 CREAM), FUSSY CUT six 4 1/2" squares.

From Fabric 11 (JT-C6711 CREAM), SELECTIVELY CUT twenty-four 4 1/2" squares.

From Fabric 12 (JT-C6711 NAVY), SELECTIVELY CUT twenty-four 4 1/2" squares.

From Fabric 13 (ERA-C9320 CHOCOLATE), cut:

- One 15 1/2" x WOF. Sub-cut twenty-eight 1 1/2" x 15 1/2".
- Two 1 1/2" x WOF. Sub-cut three 1 1/2" x 15 1/2".

From Fabric 14 (JT-C6712 NAVY), cut border strips as instructed in step 18.

From JT-C6711 CREAM, cut and piece backing.

Quilt Construction

Hour Glass (HG) Units for Blocks 1 & 2 Half-Square Triangle Sub-units

Block 1: Use two fabric 8 and one each of fabric 1 and fabric 3.
Block 2: Use two fabric 8 and one each of fabric 2 and fabric 4.

1. Place a lighter colored 5 3/4" square on top of a fabric 8 square, right sides together. Draw a diagonal line from one corner to the opposite corner. Sew 1/4" away from both sides of the drawn line.

2. Cut apart on the drawn line. Press seam allowances toward fabric 8. (figure 1)

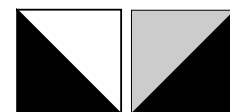

figure 1

3. Place the two Half-Square Triangles right sides together, nesting center seams. Draw a diagonal line from the top corner to the bottom corner crossing the existing seam. Stitch 1/4" on both sides of the drawn line.

4. Cut apart and press. (figure 2)
Square to 4 1/2".

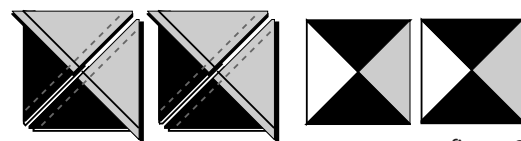

figure 2

5. Add a fabric 5 rectangle to the cream side (fabric 1 or 2) of each hour glass.

6. Repeat to make twenty-four hour-glass units and label blocks 1 and 2.

Sew-and-Flip Centers for Blocks 1 & 2:

Use six each fabric 9 and fabric 10 fussy-cut squares and the forty-eight 2 1/2" squares of fabric 8.

7. Draw a diagonal line across the center of each of the fabric 8 squares.

8. Place a fabric 8 square on one corner of a fussy-cut square, right sides together. Be sure the two edges line up. Sew just to the outside of the line, toward the corner of the larger square. (figure 3) The stitching line is shown as a dotted line on the diagram.

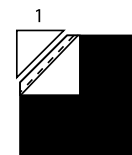
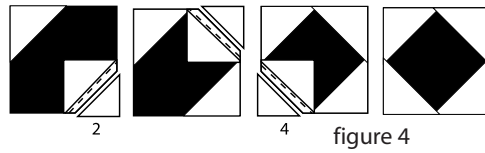

figure 3

9. Trim off the corner, leaving a 1/4" seam allowance. Press the seam allowance toward the small triangle. Using this same technique, add small squares to all four corners of the larger square. (figure 4) *NOTE: The small squares will*

overlap in the middle of each side.

10. Repeat to make twelve center squares. Separate into two piles of six and label for Blocks 1 (dark center) and 2 (light center).



Corner Units for blocks 1 & 2

Using twenty-four each of fabrics 11 and 12 large sunflower squares and all the fabric 6 and 7 rectangles, make a total of forty-eight corner units.

10. Sew the fabric 6 rectangles (red vine) to the right side of all forty-eight sunflower squares. Press away from the corner square.

11. Sew the fabric 7 (green) rectangles to the bottom of each newly formed unit. Press away from the corner square. *Corner Units must be constructed as written.*

12. Separate into two piles of twenty-four and label for blocks 1 (dark) and 2 (light)

Assembling Blocks 1 & 2

Each block uses nine units: four hour-glass units, one center sew-&-flip unit and four corner units. For Block 1, use the sew-&-flip blocks with a dark center and the fabric 1 hour-glass blocks.

For Block 2, use the sew-&-flip blocks with a light center and the fabric 2 hour-glass blocks.

13. Refer to the block diagrams and lay out the nine units in three rows of three units each. Sew together the units in each row and then sew the rows together.

14. Repeat to make a total of six each of Blocks 1 and 2.

Assembling the Quilt Top

15. Refer to the quilt photo and make four rows of three blocks each. Each row should alternate sashing strips and blocks as shown. Pay close attention to the placement of the light and dark corners. Press seam allowances toward sashing.

16. Create five connecting rows alternating remaining sashing strips and gold cornerstones. Press away from cornerstones.

17. Sew block rows and connecting rows together to make the quilt top.

Mitered-Corner Borders

18. Cut length of fabric border strips from the focal border stripe as shown in the border stripe detail. Cut on the black line between the red and gold stripes on the outside of each daisy section. Set daisy stripes aside for binding. The four sunflower stripes will be used for the borders.

19. Sew two WOF Border strips of fabric 8 together end-to-end with a straight seam. Repeat with pairs of the remaining fourteen WOF strips to make a total of eight long inner and outer border strips.

20. Sew the long red strips to either side of each sunflower border strip. Press toward fabric 8.

21. Find the centers of all four sides of your quilt and the four border strips. Mark the centers with pins.

22. Pin a border strip to one side of the quilt matching center pins. At least 10" of border must extend beyond each end of the quilt. (figure 5) Start sewing 1/4" from the end of the quilt. Sew a couple of stitches, backstitch to lock the seam and sew to within 1/4" of the other end of the quilt. Backstitch again to lock the seam. Do NOT trim off the excess border strip. Repeat to add borders to the remaining three sides of the quilt.

23. Refer to figure 6 for instructions on how to fold, mark and stitch the mitered corners.

24. Open the mitered corners and press. (figure 7) Check to be sure that you are satisfied with the mitering

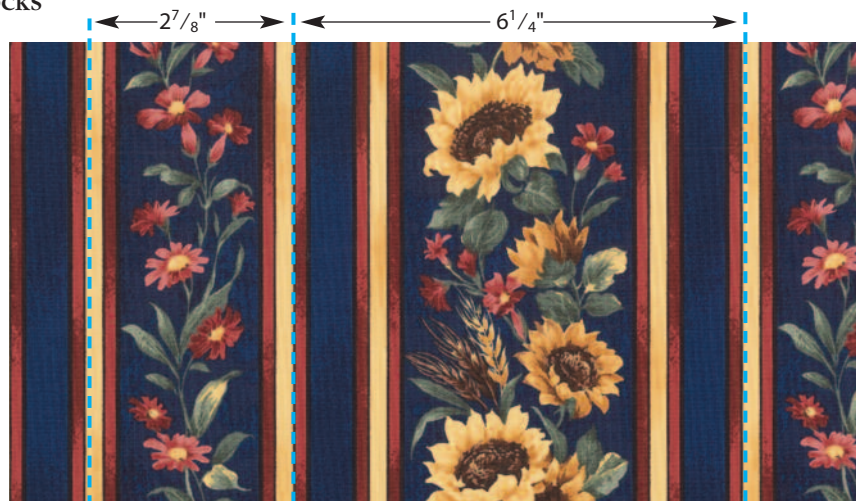
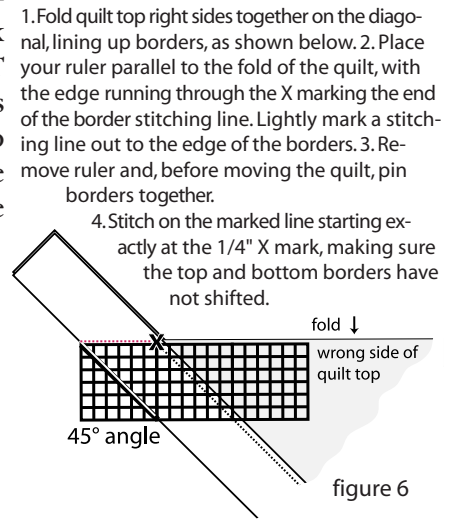
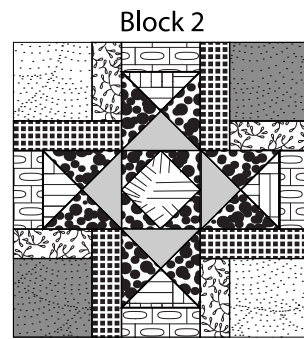
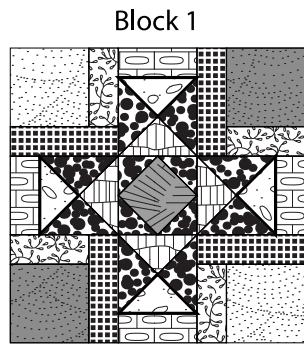
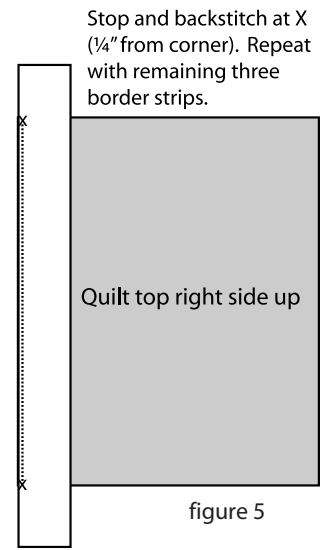

BORDER STRIPE DETAIL—Cutting lines shown as dotted lines. (FABRIC 14: JT—C6712 NAVY)

before trimming away excess fabric.

Finishing Instructions

25. Sandwich the quilt top, batting and backing and quilt as desired.

26. Place two binding strips (daisy stripes reserved from the border fabric) right sides together at a 90° angle. (figure 8) Stitch across the intersection of the two strips on a 45° angle. Trim the seam allowance to 1/4". Repeat, adding the rest of the

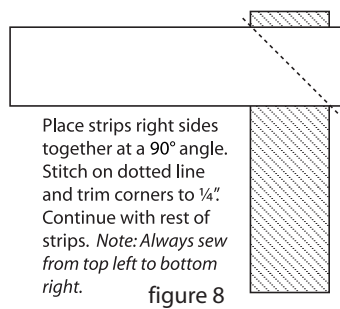
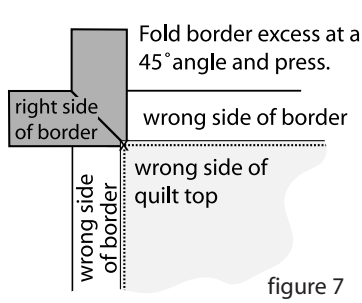

binding strips. (Note: Always sew from top left to bottom right.)

27. Fold the binding in half lengthwise, wrong sides together, and press.

28. Baste the binding to the front of the quilt, matching raw edges. Sew

on binding, mitering around the corners.

29. Fold the binding over the raw edges and stitch to the back of the quilt by hand.

on binding, mitering around the corners.

29. Fold the binding over the raw edges and stitch to the back of the quilt by hand.



FABRIC 1: JT-C5840 CREAM Hour-Glass Units, Block 1

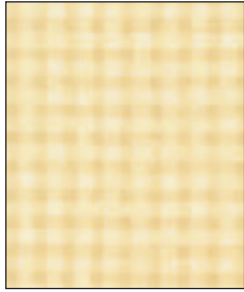

FABRIC 2: JT-C5841 CREAM Hour-Glass Units, Block 2



FABRIC 3: JT-C5837 YELLOW Hour-Glass Units, Block 1



FABRIC 4: JT-C5837 GOLD Hour-Glass Units, Block 2 & Sashing Cornerstones

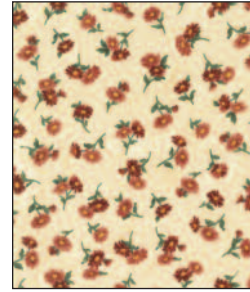

FABRIC 5: JT-C6713 CREAM Hour-Glass Units

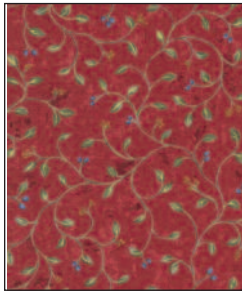

FABRIC 6: JT-C5840 RED Corner Units

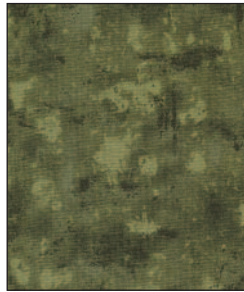

FABRIC 7: JT-C5837 PINE Corner Units



FABRIC 8: JT-C5837 RED Hour-Glass & Center Units



FABRIC 9: JT-C6714 NAVY Center Units, Block 1



FABRIC 10: JT-C6714 CREAM Center Units, Block 2



FABRIC 11: JT-C6711 CREAM Corner Units



FABRIC 12: JT-C6711 NAVY Corner Units

ALL FABRICS THIS PAGE SHOWN 25% OF ACTUAL SIZE.



FABRIC 13: ERA-C9320 CHOCOLATE Sashing

©2010 Wing And A Prayer Design
(620) 767-6628

www.wingandaprayerdesign.com

Permission is granted to shop owners and teachers to make copies for promotional or educational purposes only.

This pattern may not be reproduced for commercial purposes (i.e may not be sold).

This pattern may not be reproduced for ANY PURPOSE after April 1, 2011.